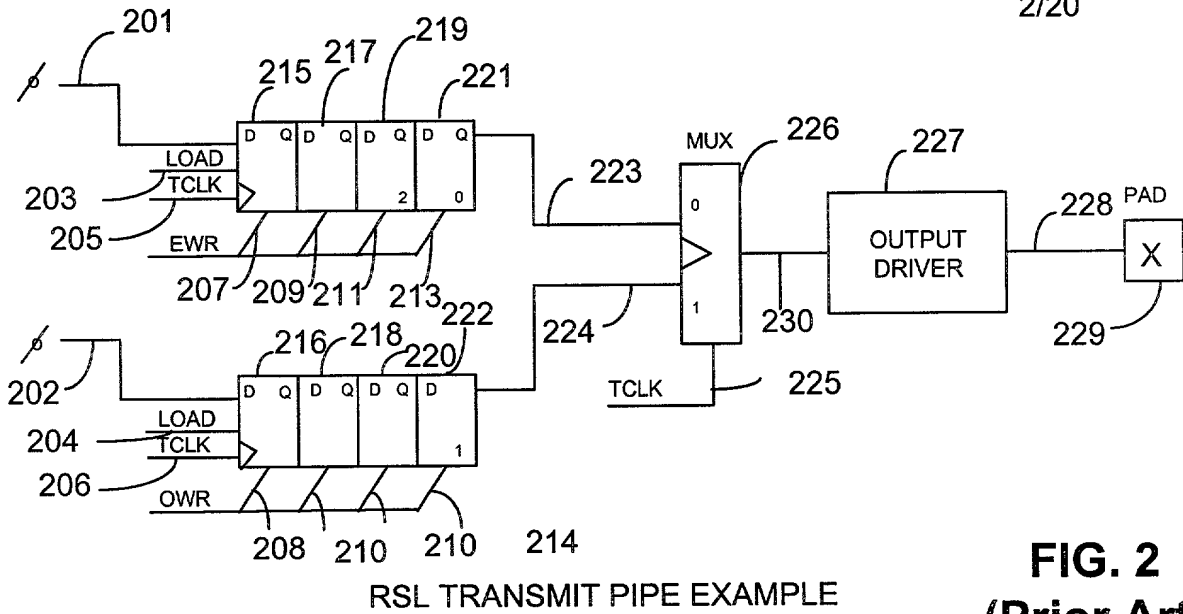
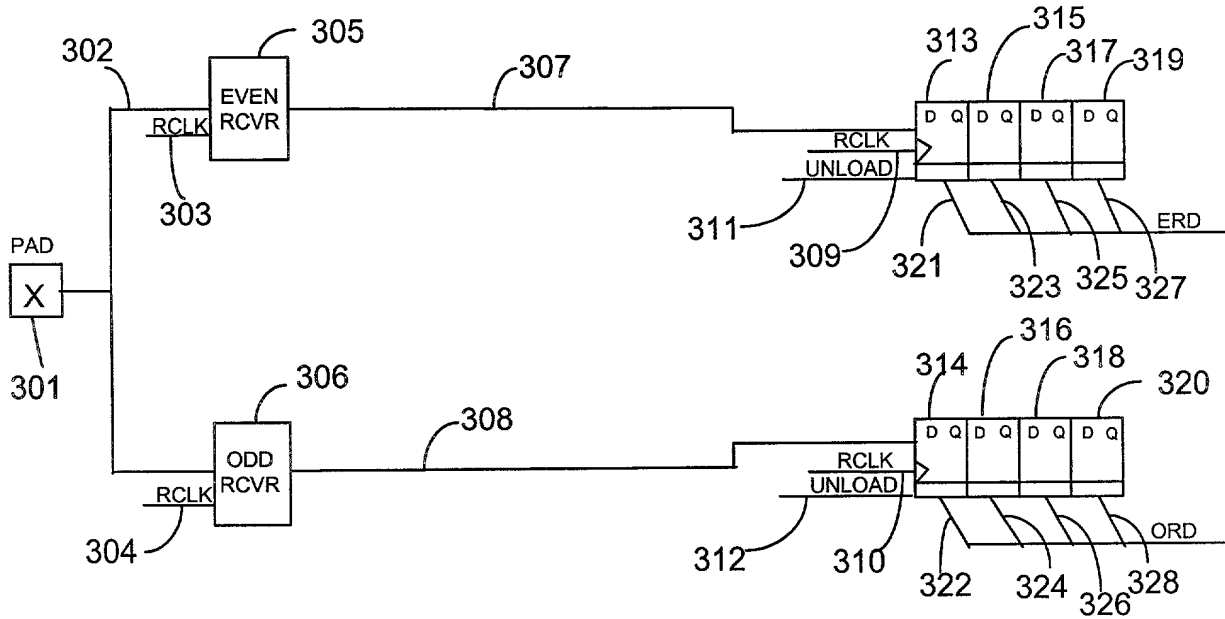


FIG. 1



**FIG. 2**  
**(Prior Art)**

**RSL RECEIVE PIPE EXAMPLE**



**Fig. 3**  
**(Prior Art)**

Patent Application No. 2004/0100000

RSL TRANSMIT PIPE WITH PRBS TEST MODE

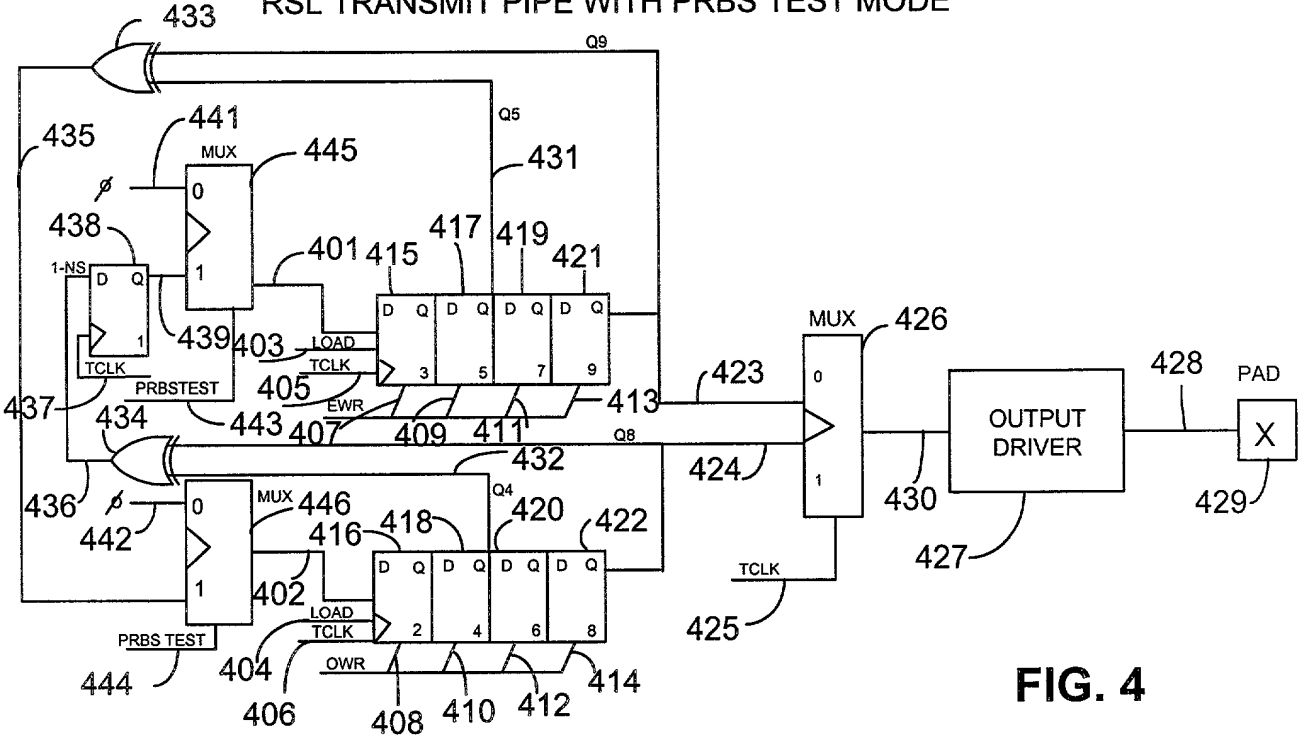


FIG. 4

RSL RECEIVE PIPE WITH PRBS TEST MODE

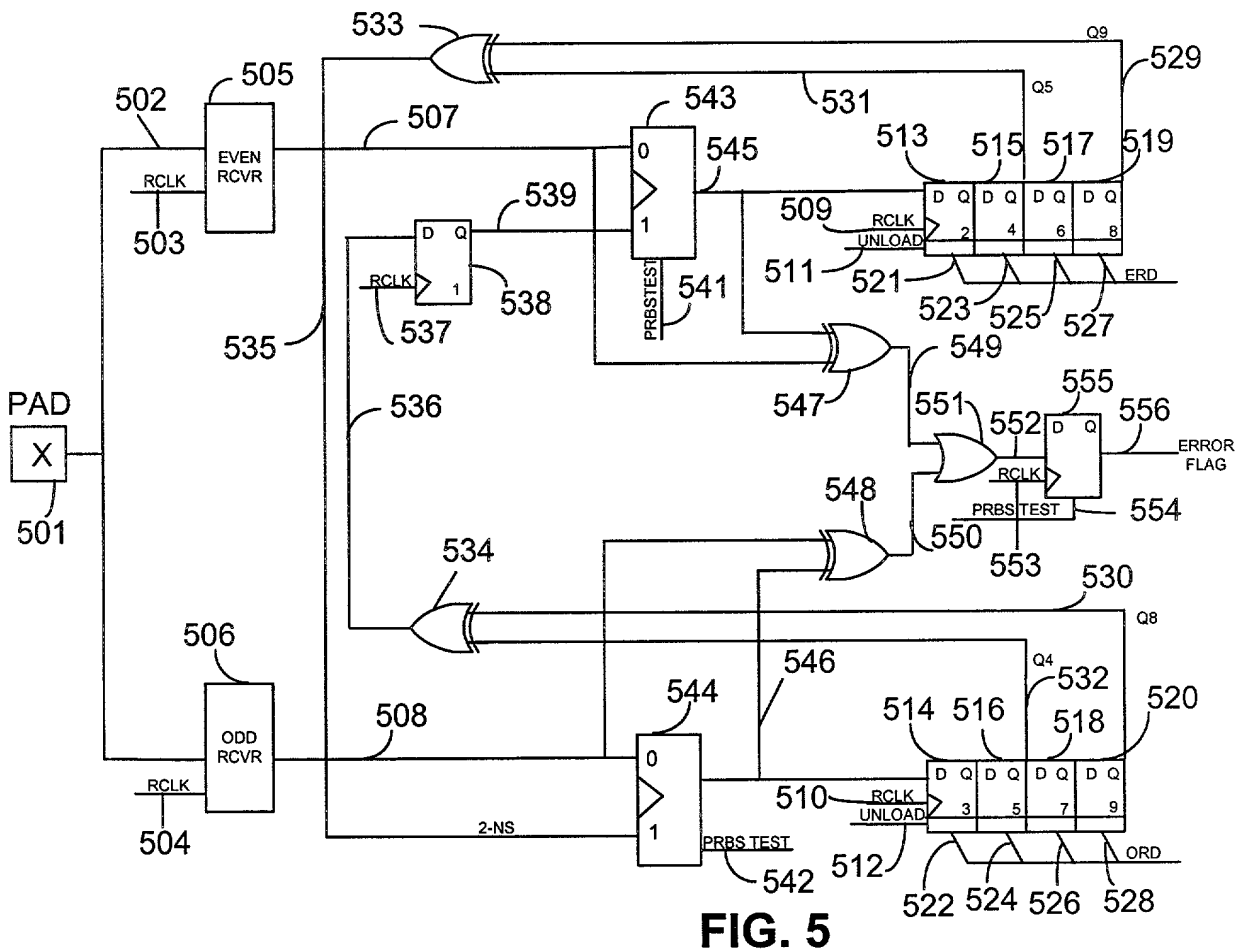


FIG. 5

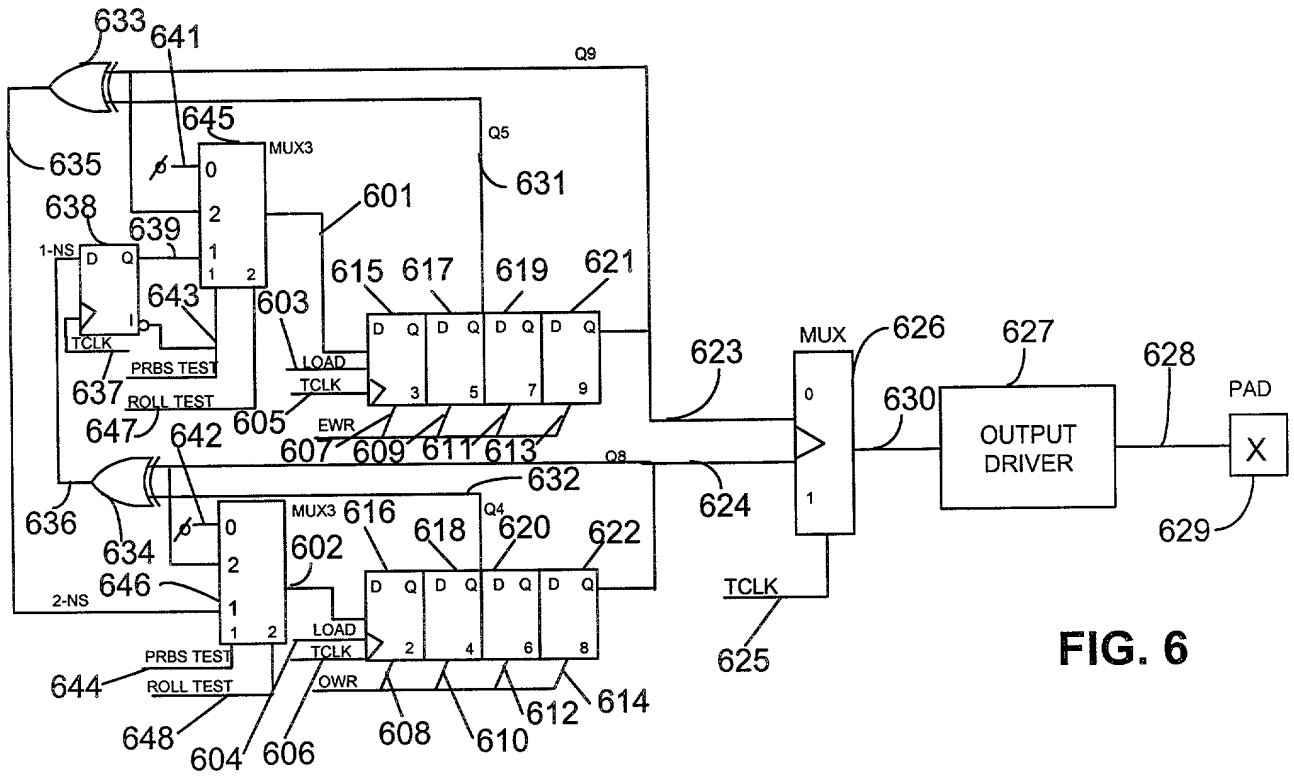


FIG. 6

RSL RECEIVE PIPE WITH PRBS AND ROLL TEST MODE

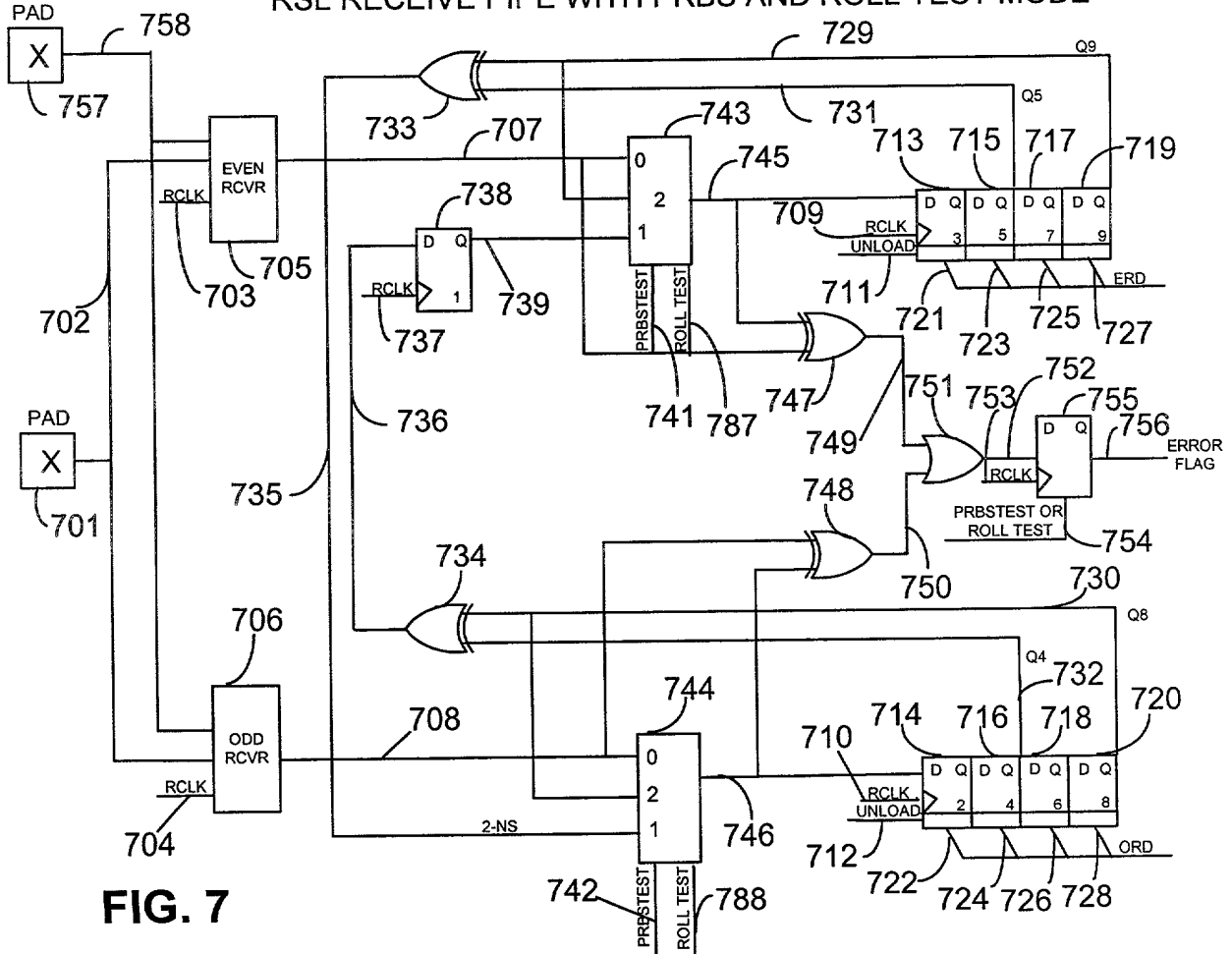
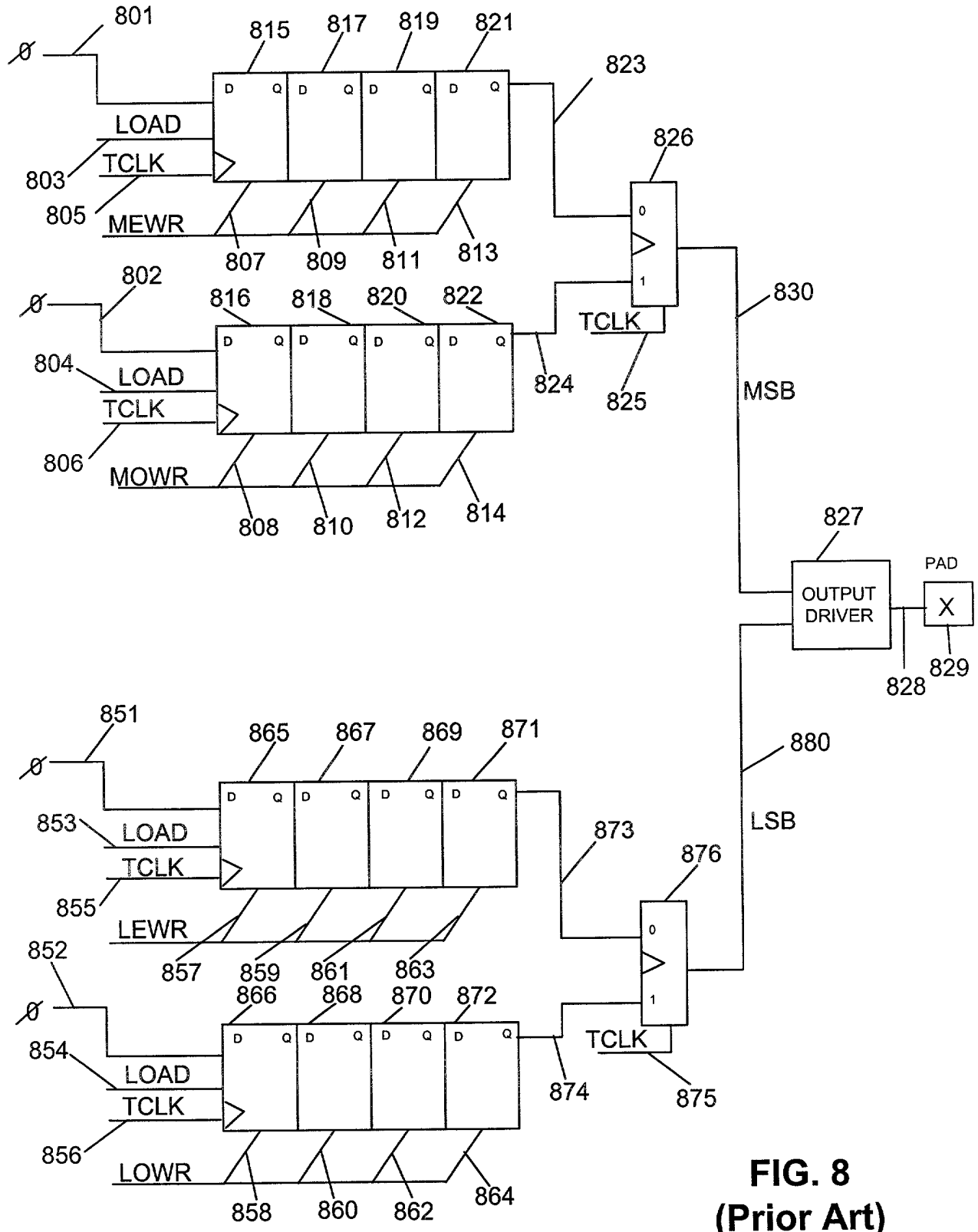


FIG. 7



**FIG. 8**  
**(Prior Art)**

FIG. 8 (Prior Art)

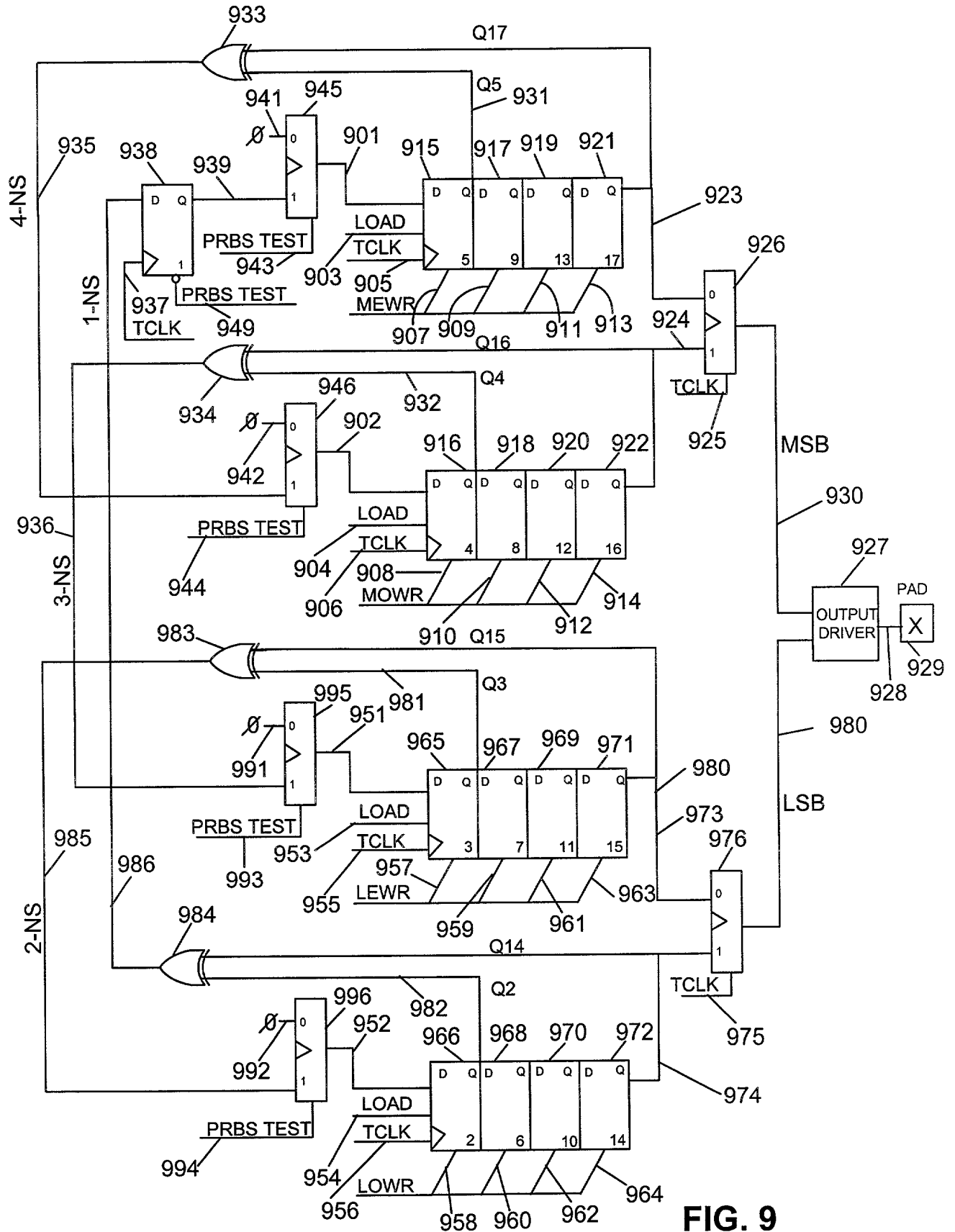


FIG. 9

Copyright © 2006 Intel Corporation. All rights reserved.

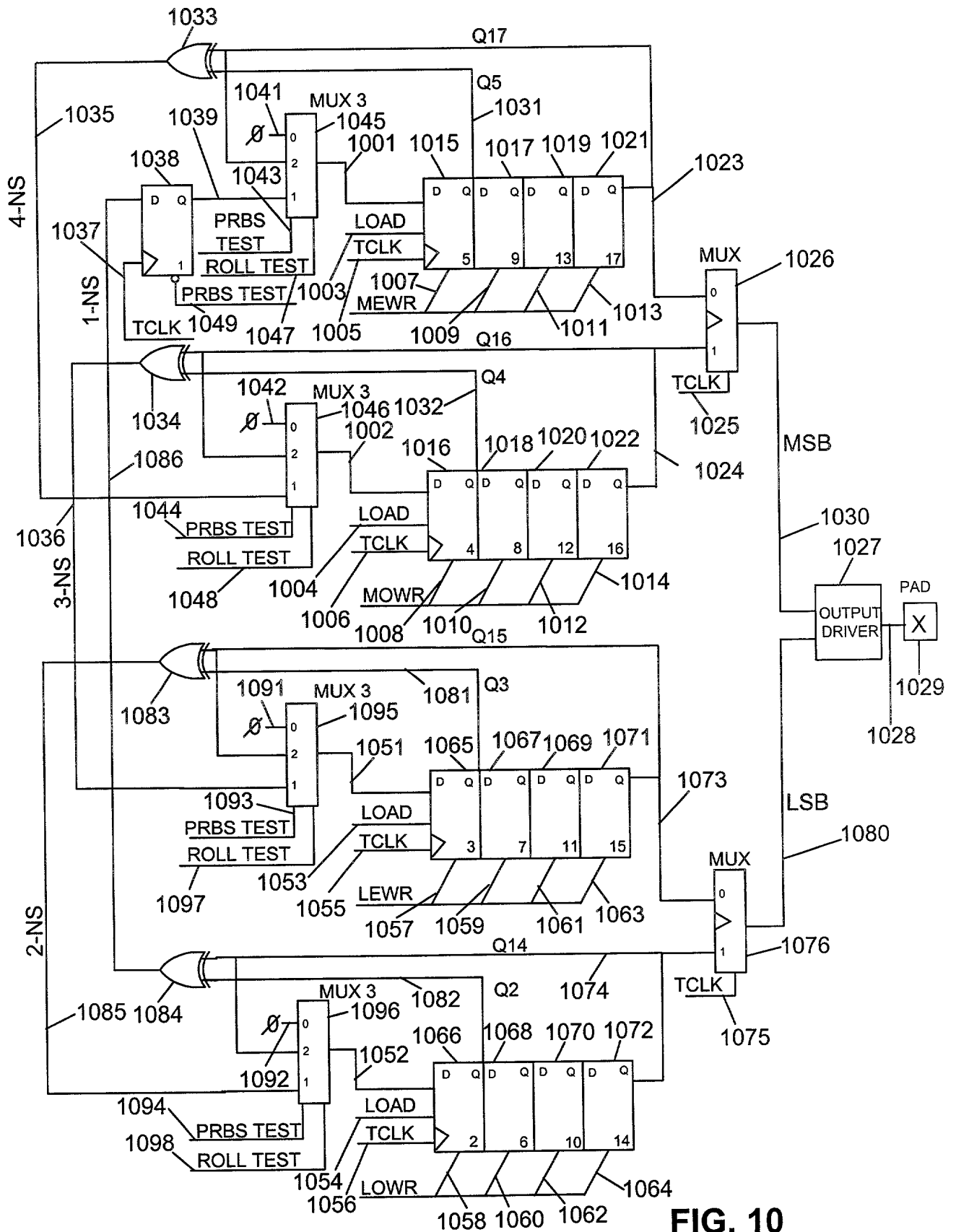
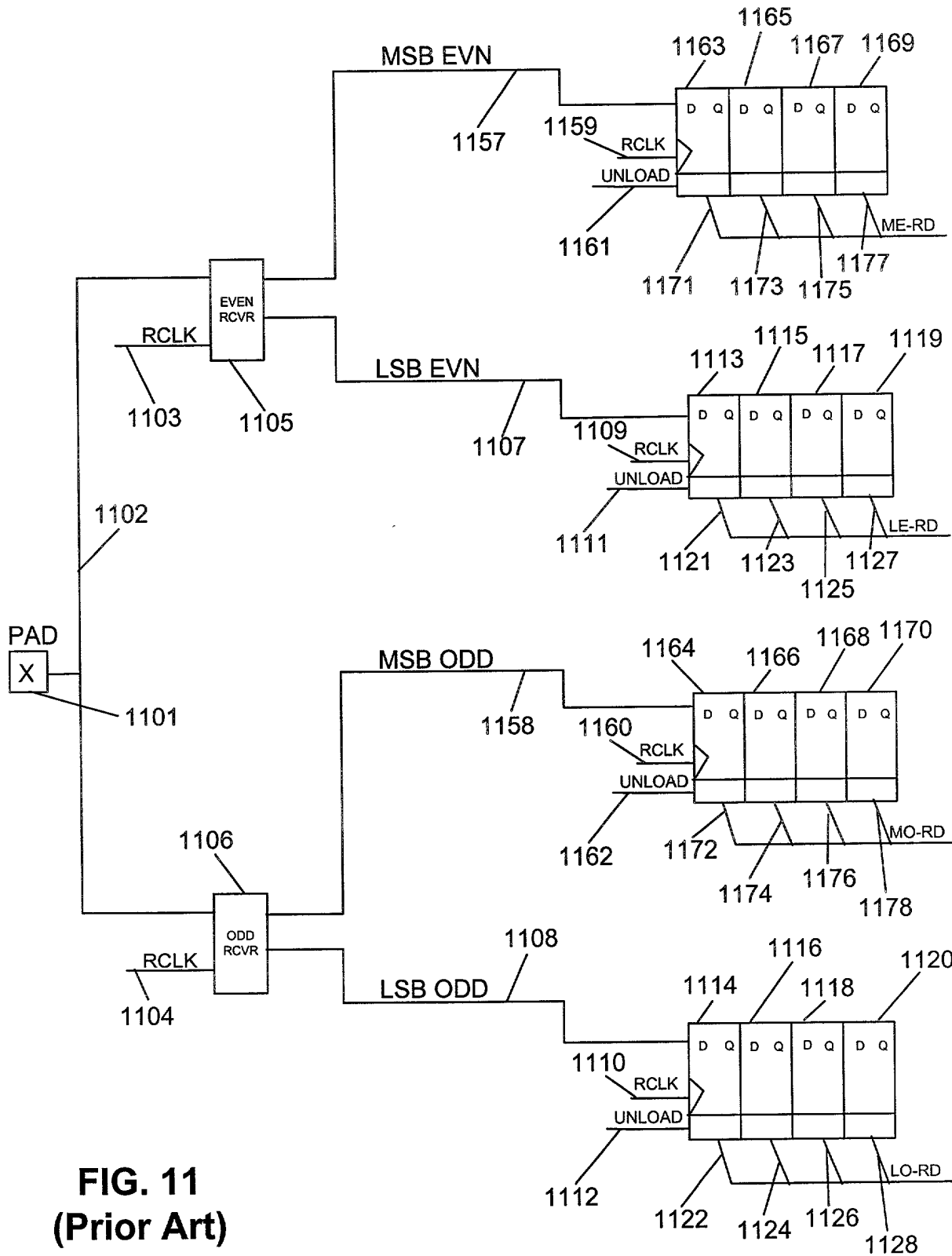


FIG. 10



**FIG. 11**  
**(Prior Art)**

2025 RELEASE UNDER E.O. 14176



QRSL RECEIVE PIPE WITH PRBS TEST

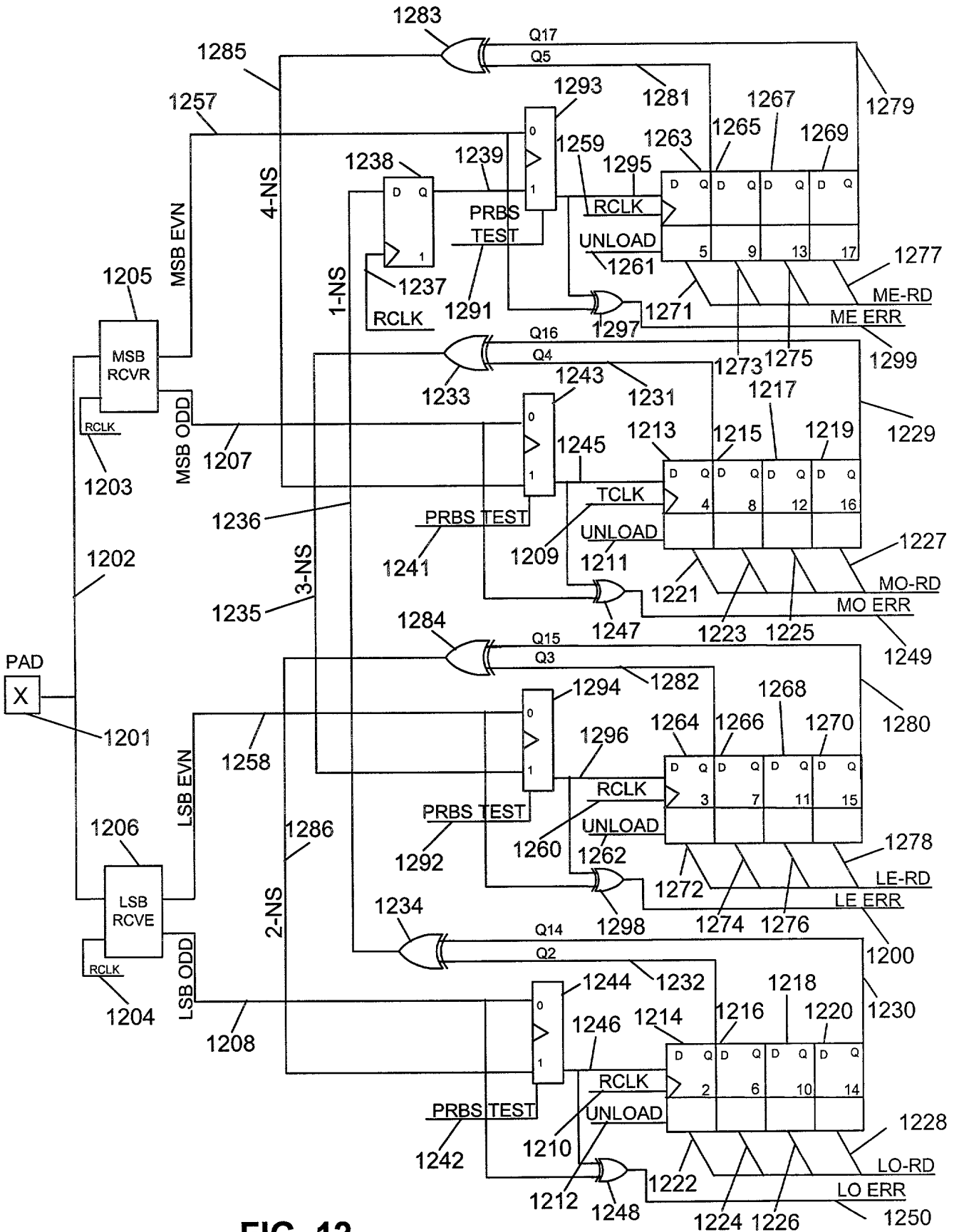


FIG. 12

QRSL RECEIVE PIPE WITH PRBS AND ROLL TEST

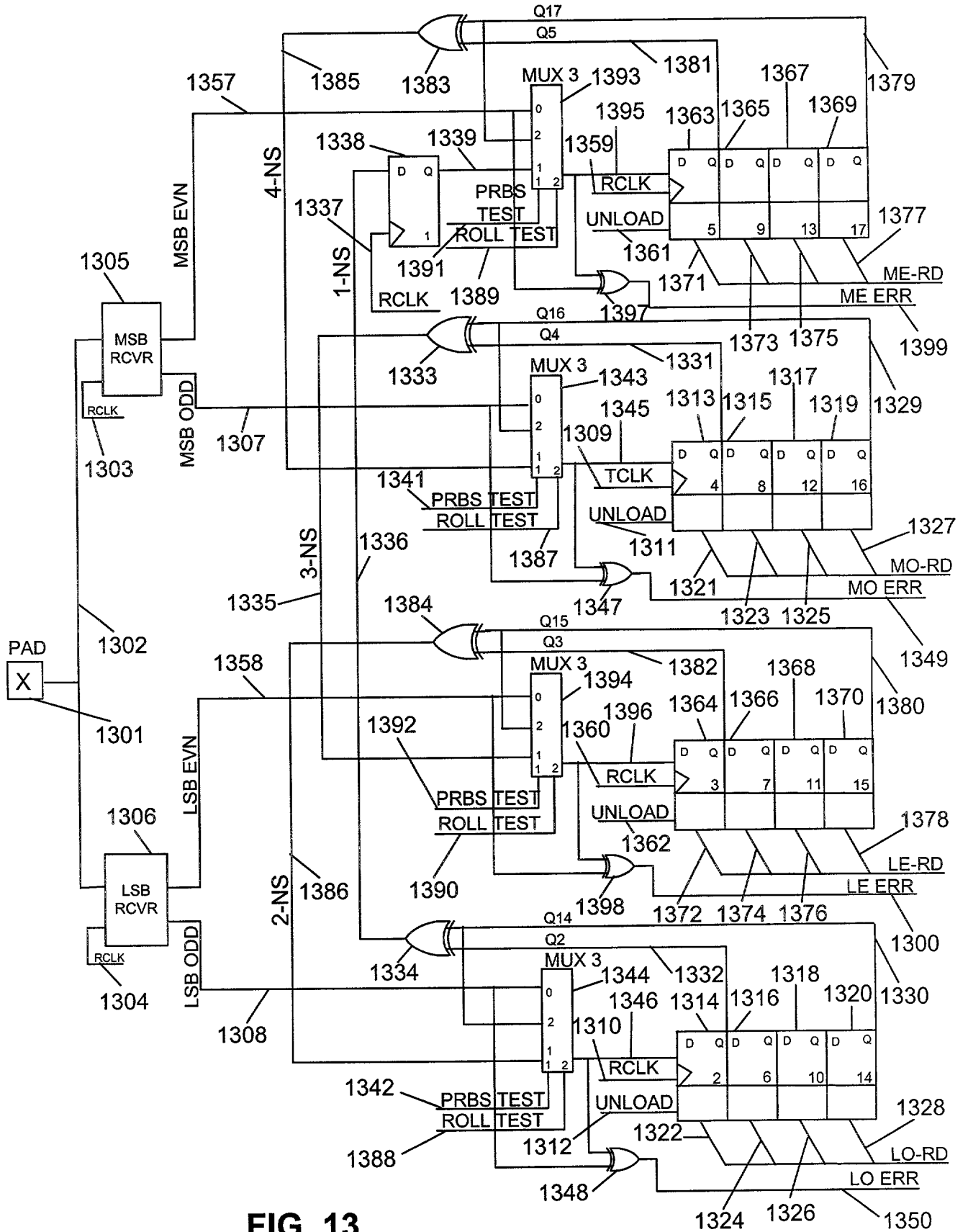


FIG. 13

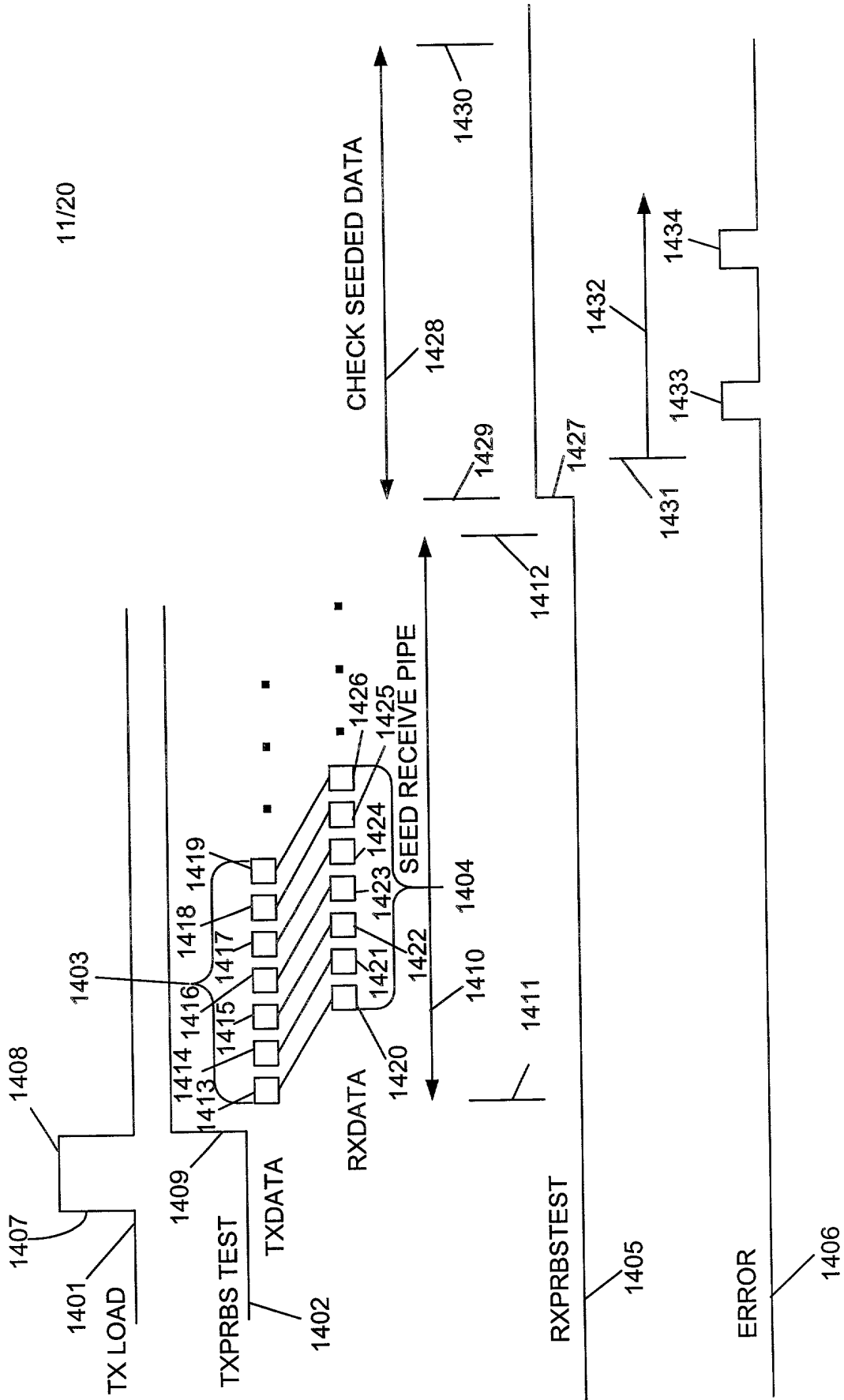


FIG. 14

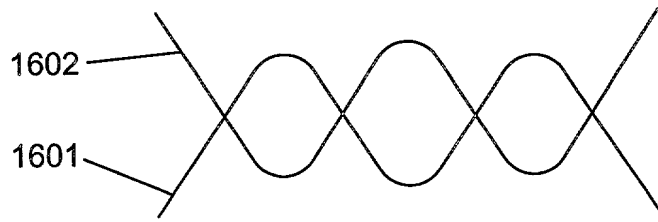


FIG. 16

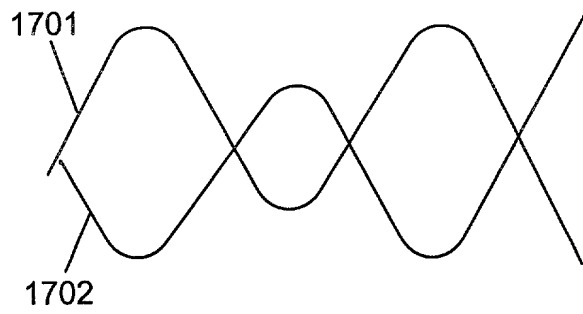


FIG. 17

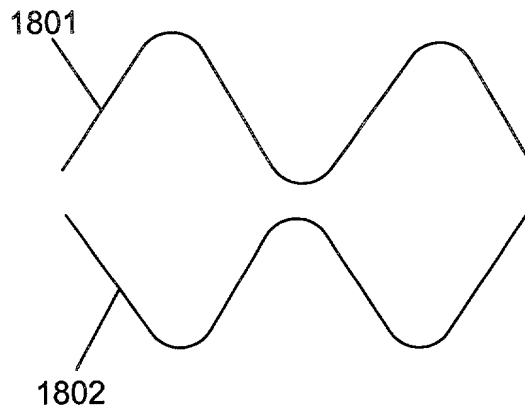


FIG. 18

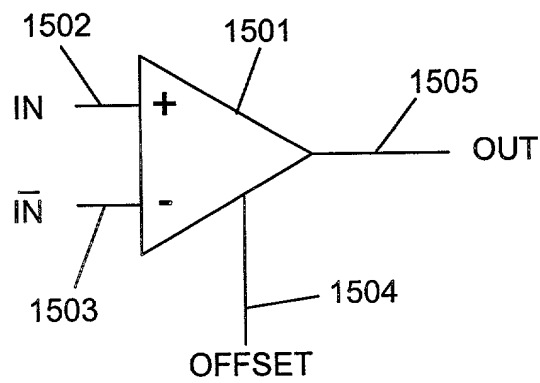


FIG. 15

FIG. 15

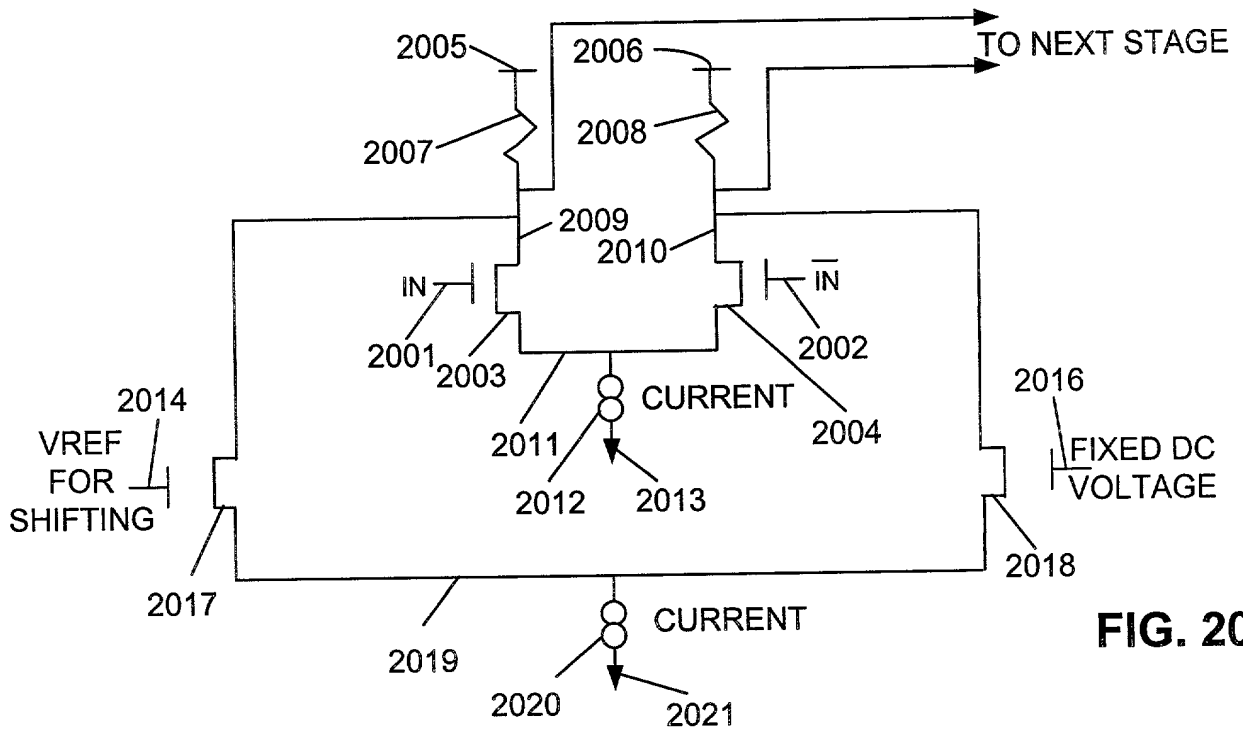


FIG. 20

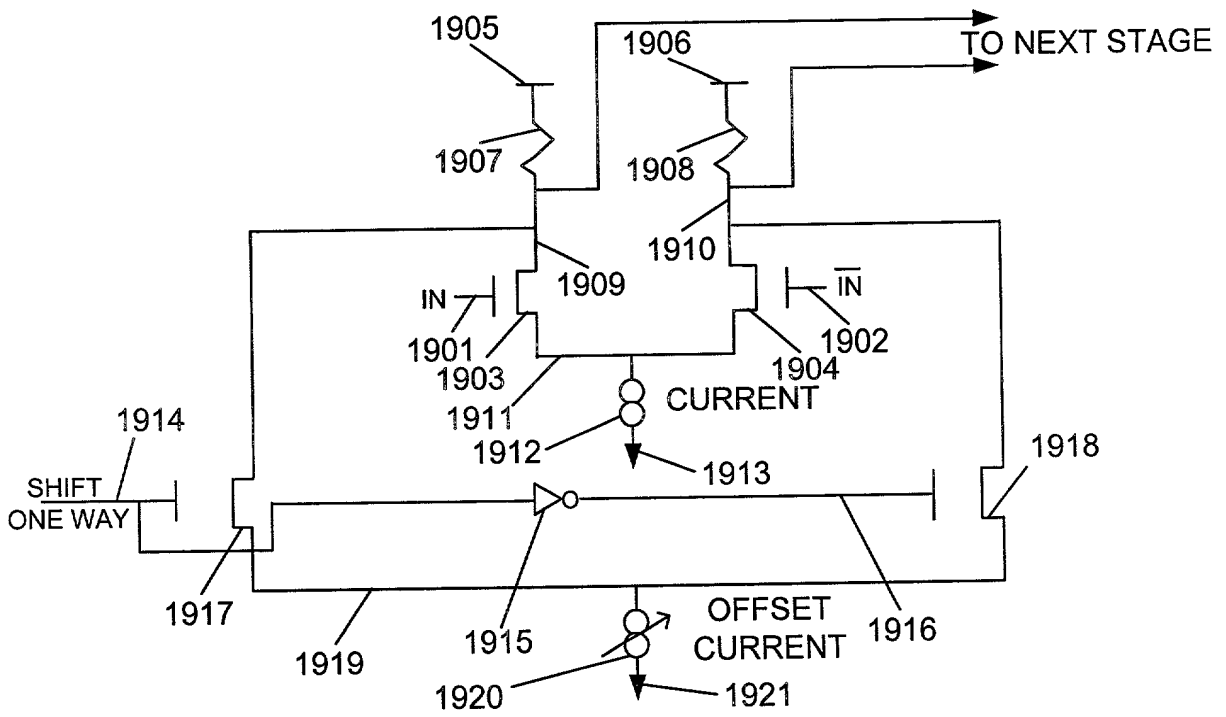
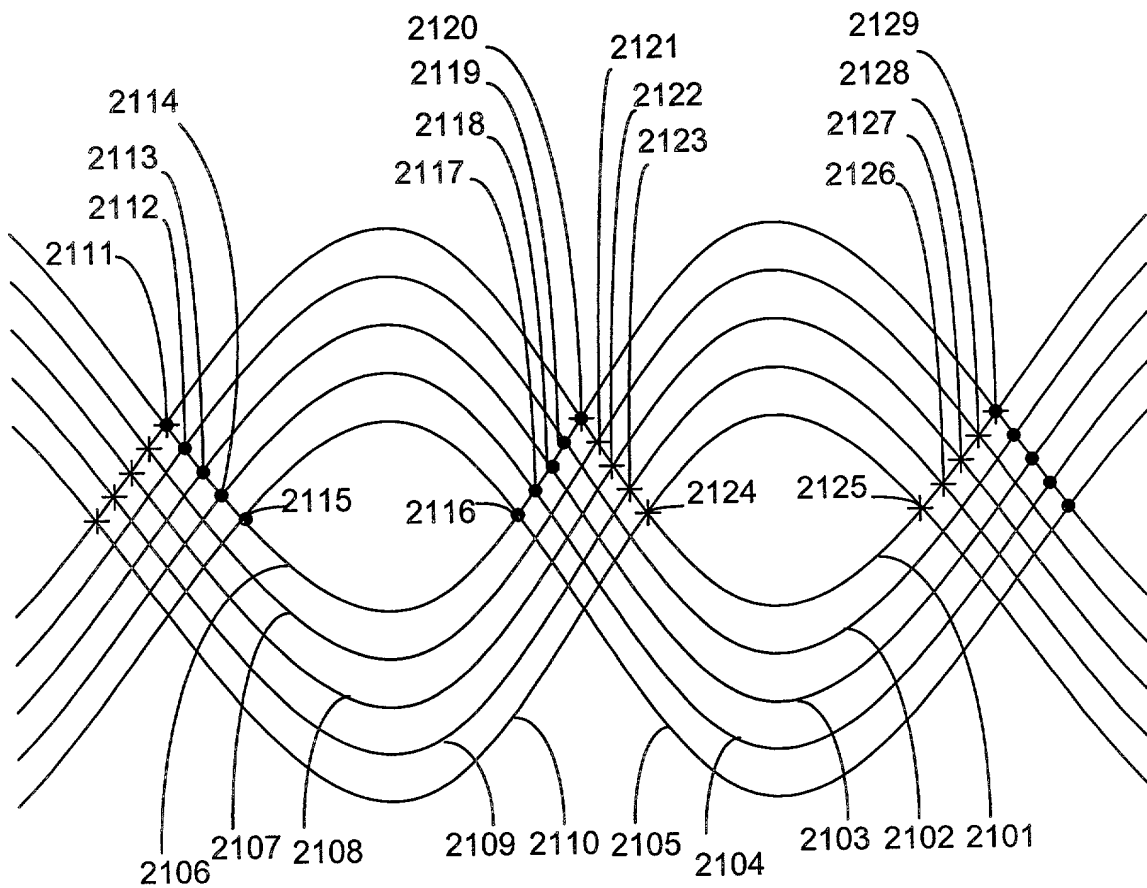
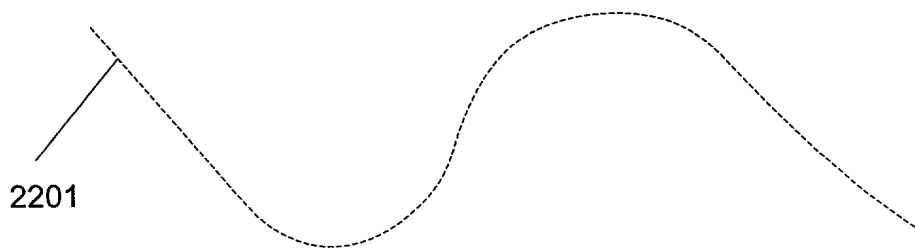


FIG. 19



**FIG. 21**



**FIG. 22**

FIG. 21

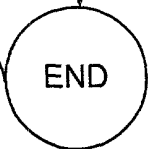
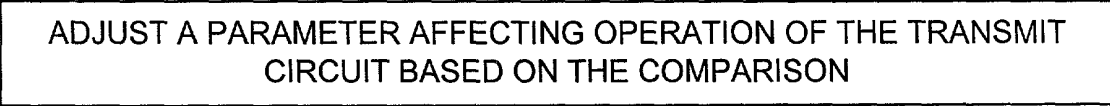
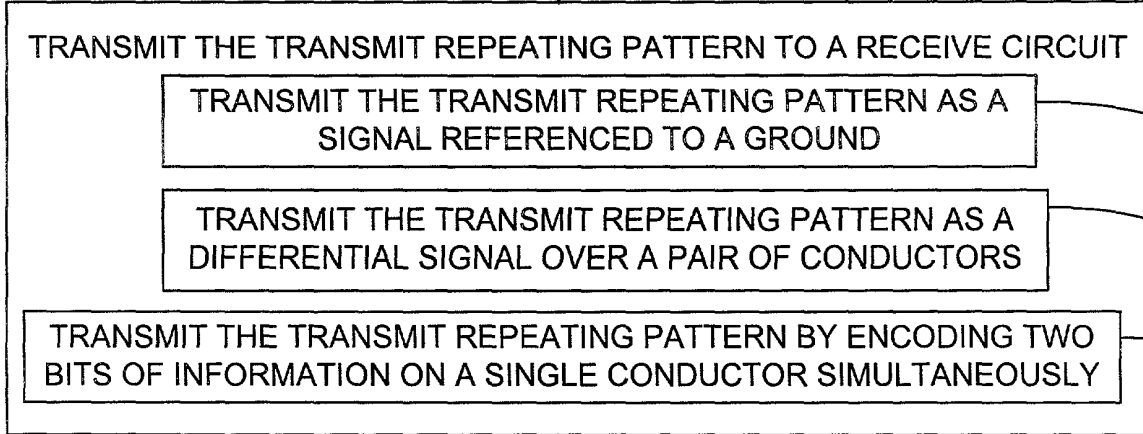
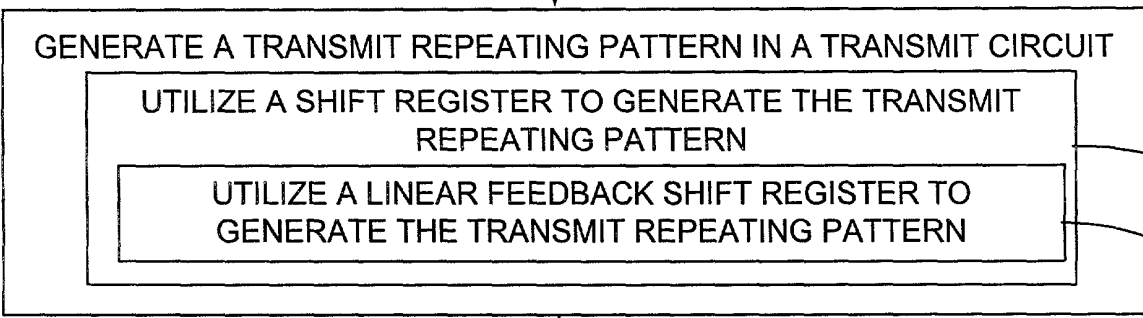
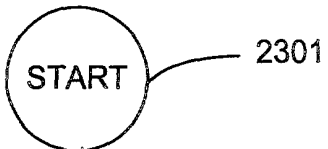
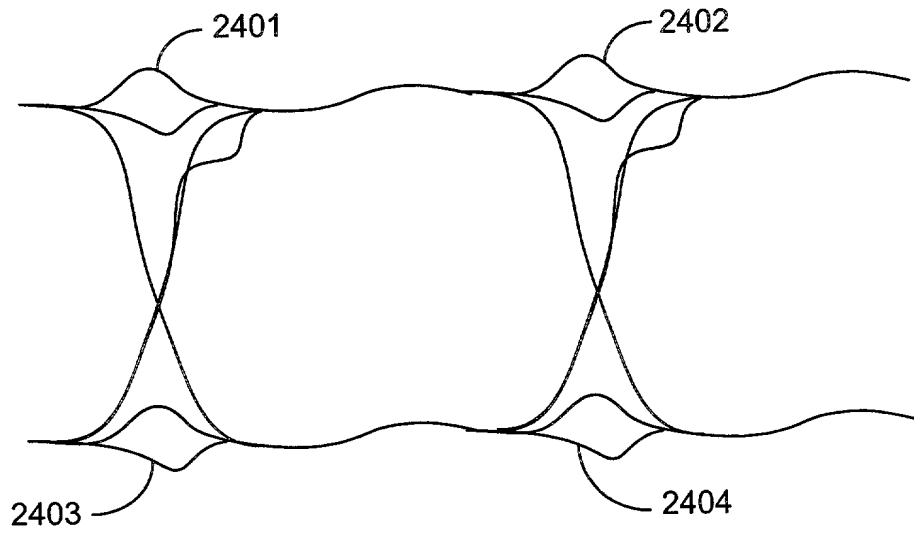
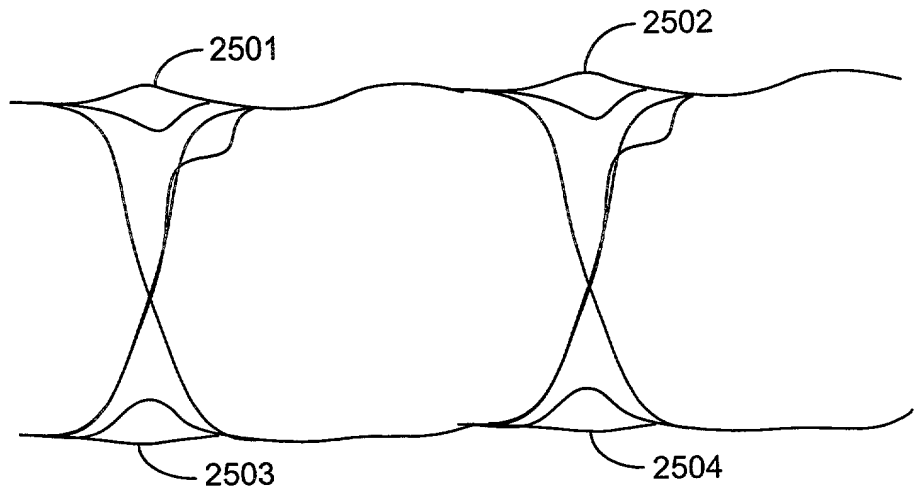


FIG. 23

FIG. 23



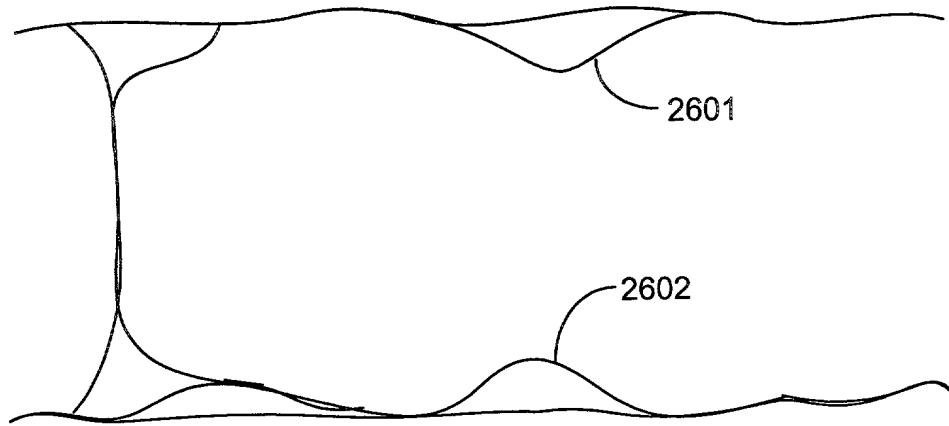
**FIG. 24**



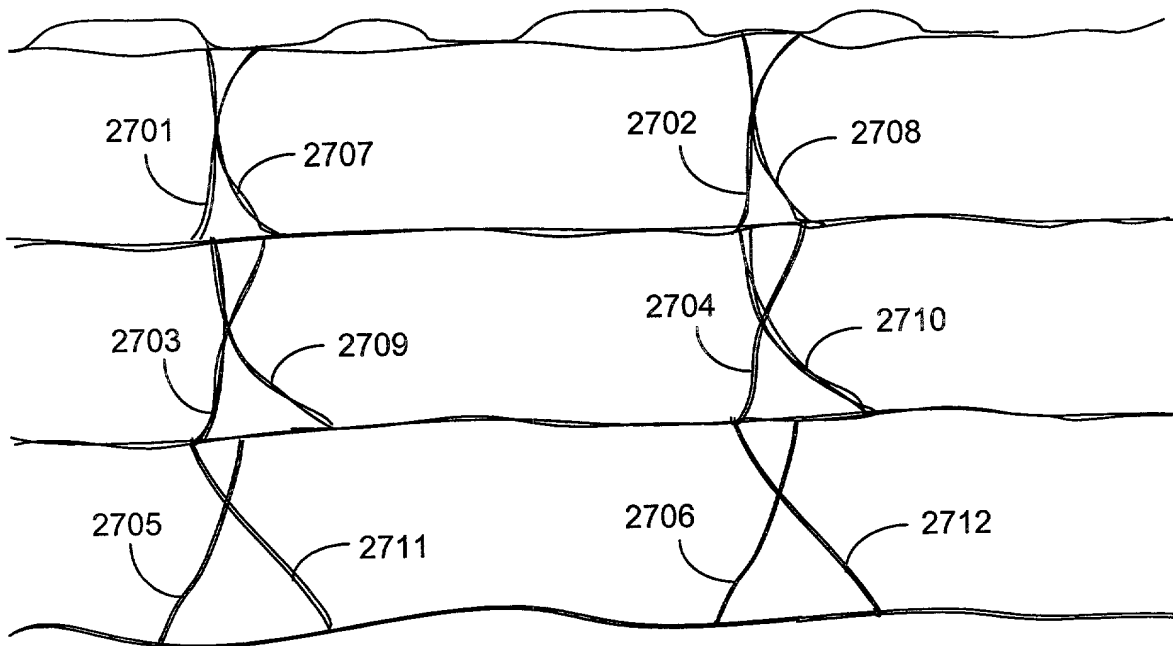
**FIG. 25**

FIG. 24



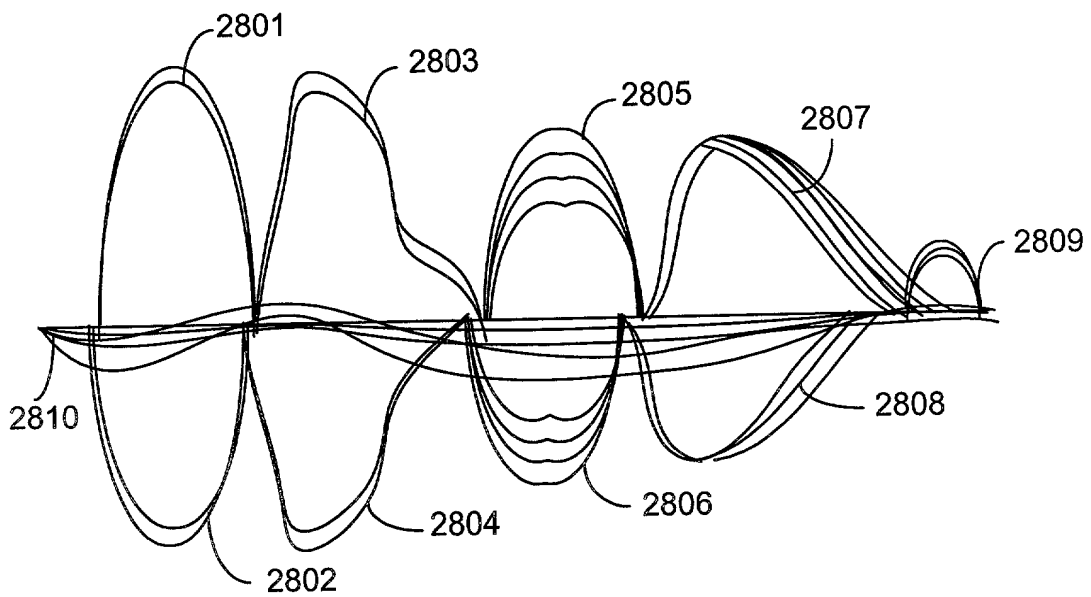


**FIG. 26**

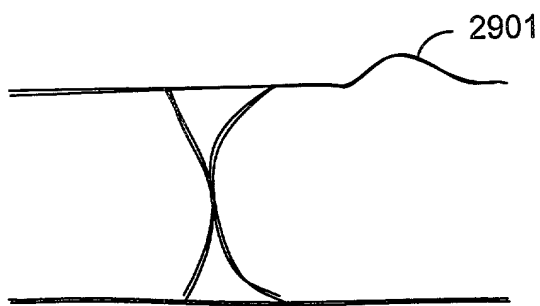


**FIG. 27**

17/20



**FIG. 28**



**FIG. 29**

Patent Application No. 2009/0000000

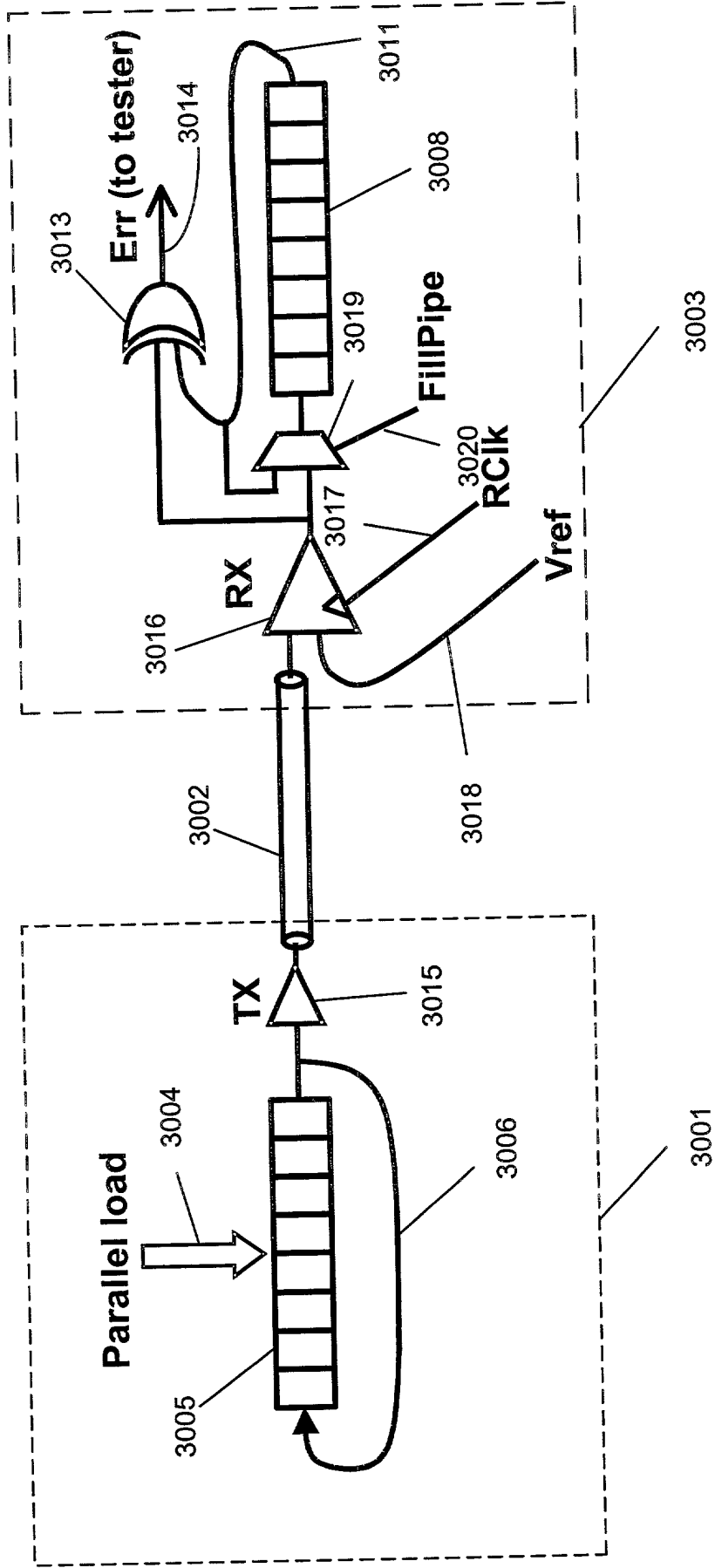


FIG. 30

FIG. 31

